

MACARENA
activity centre



” 2001/95/ ”
EN 14036:2003 ”
/ ”

2009/48/ ” ”

❖ , 11 kg , 76 cm.
 ❖ - 6 .
 ❖ : - ;
 ❖ ;
 ❖ : 2 , 3 AA (LR6) 1,5V () .

! , , ,

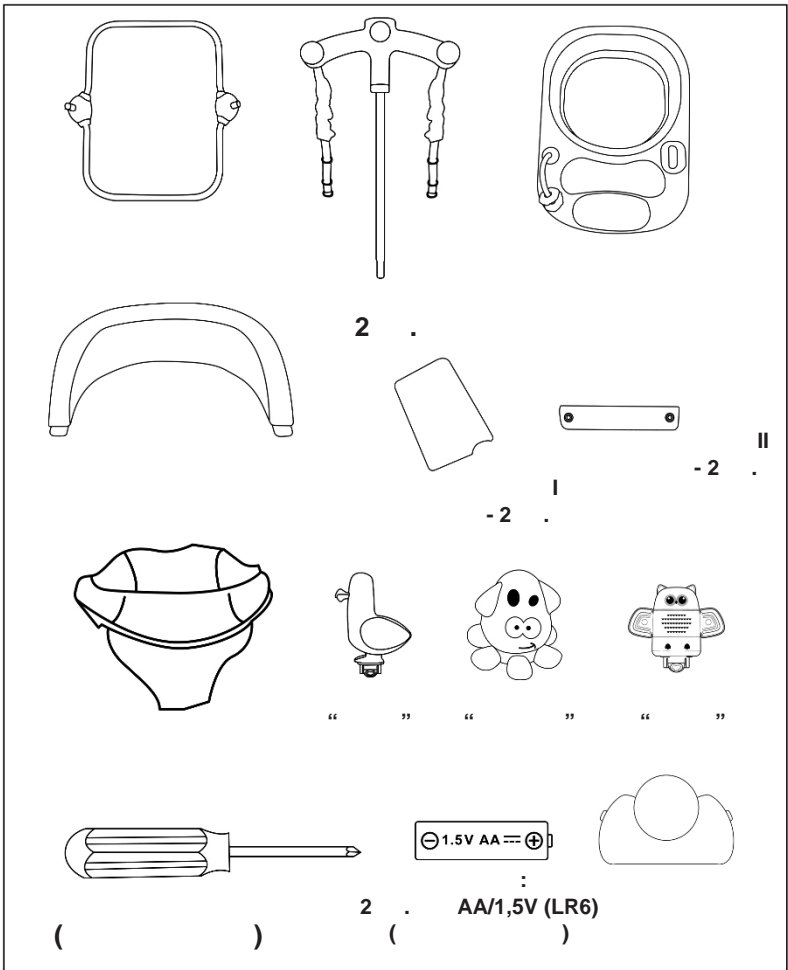



ЗАБЕЛЕЖКА:

() . 1 9 .

1 -

1-1 - „I“ „II“.

1-2 -

2 -

3 -

_____ :

4 -

5 -

_____ :

” “

_____ :

6 -

7 -

8 -

		1	e 4
		2	9
		3	8
	/		

1.

Забелешка:

2. , /1,5V,

3.

9 –

9-1 –

3

9-2 –

9-3 – !

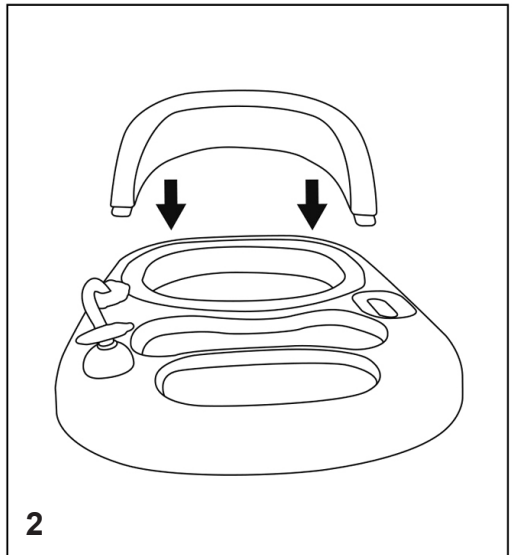
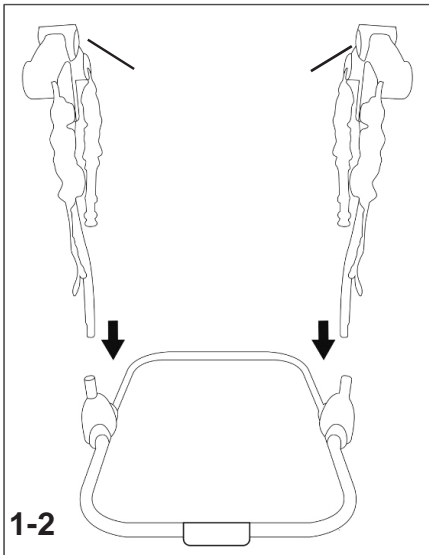
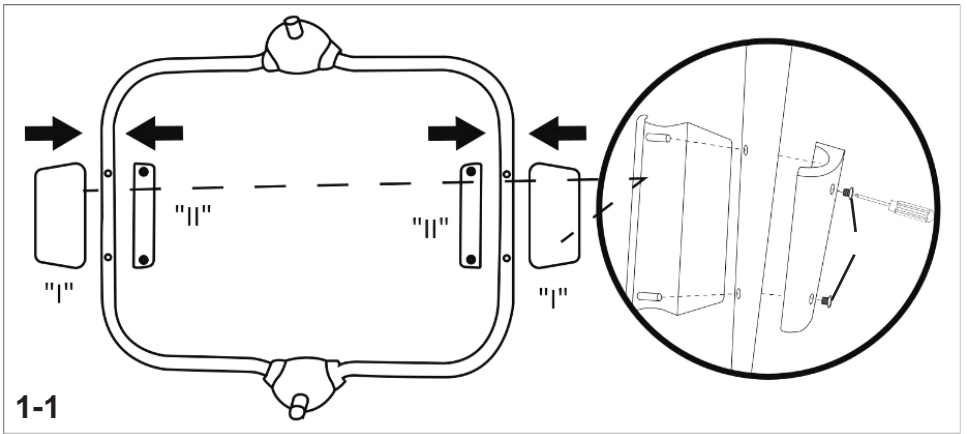

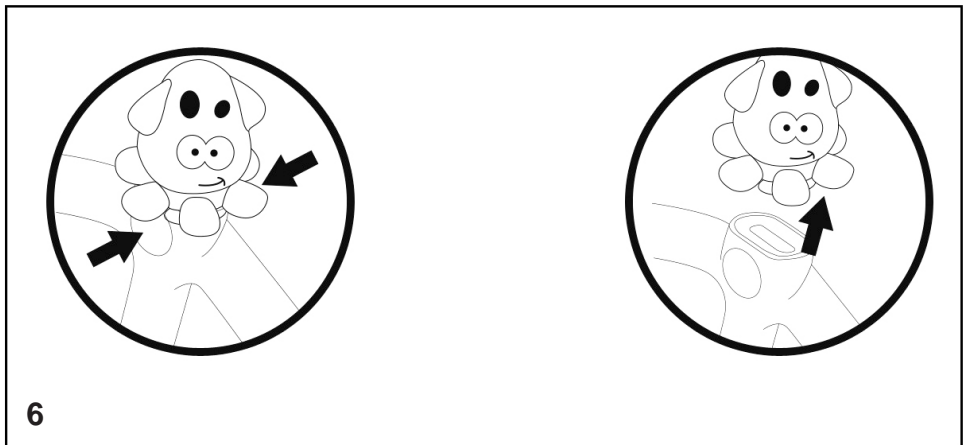
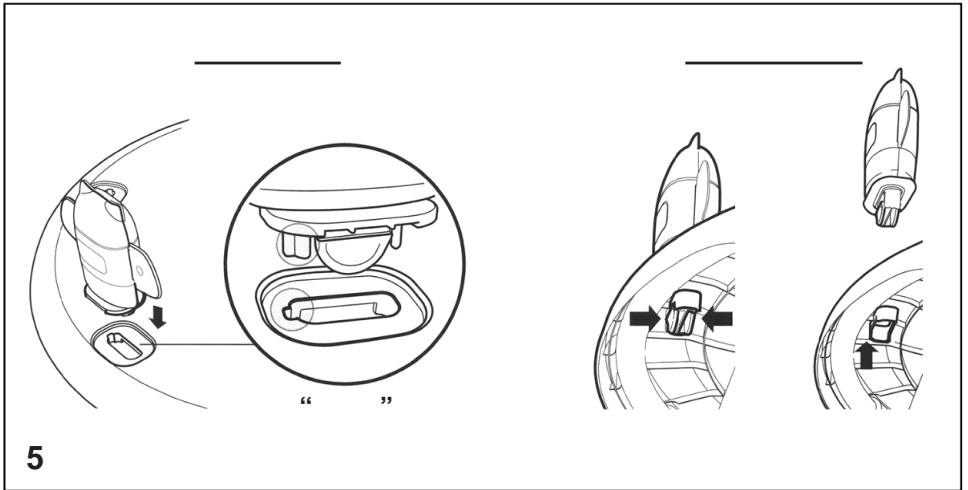
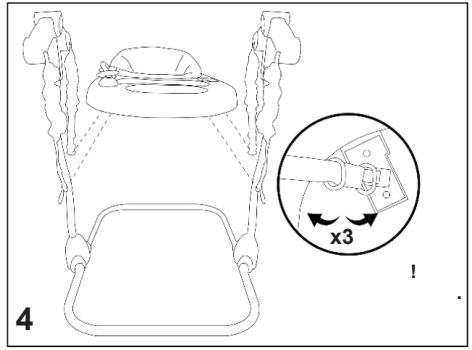
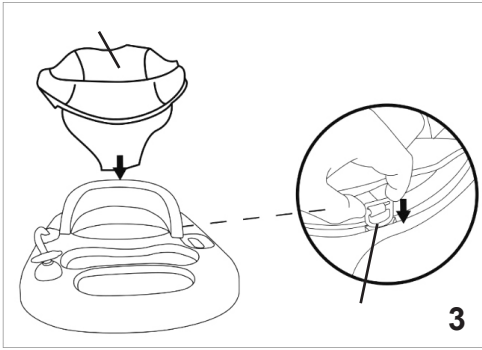

7

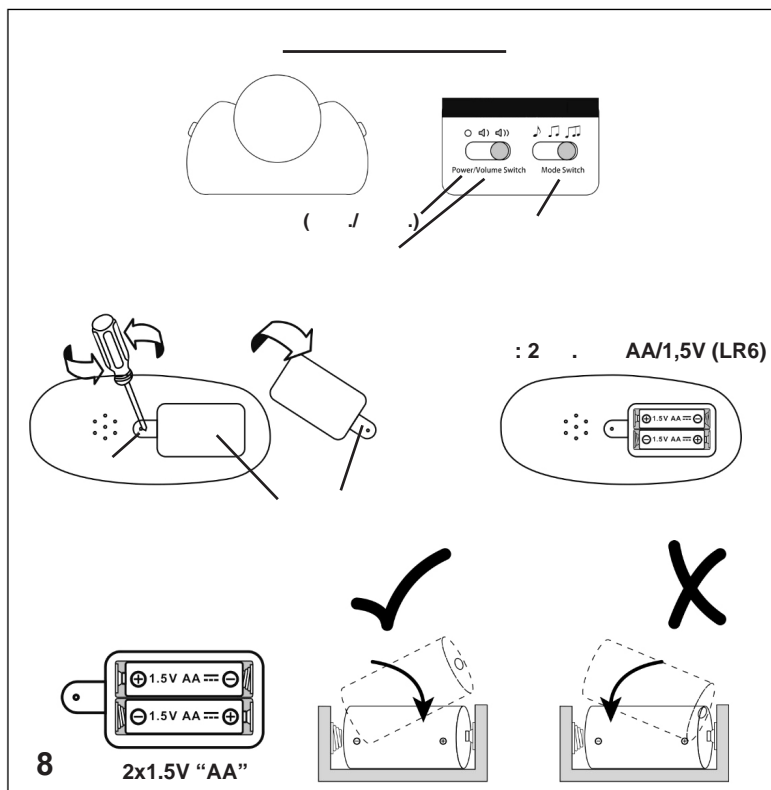
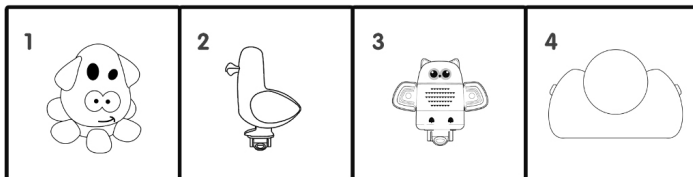
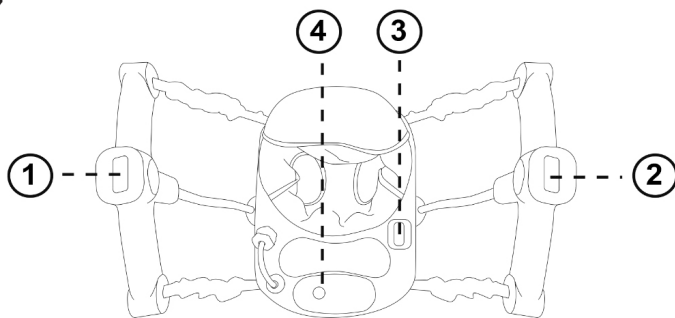

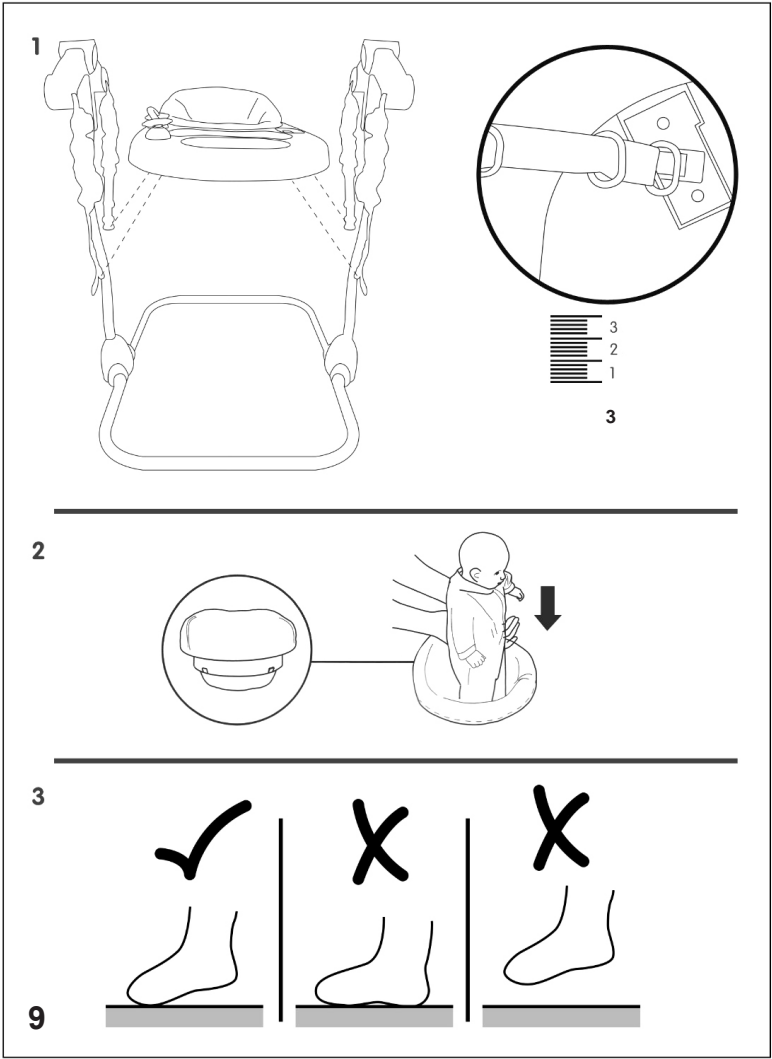



- ❖
- ❖
- ❖
- ❖
- ❖
- ❖
- ❖
- ❖
- ❖
- ❖

30°

: 100 %
: 100%



PRMC0230xxx / CH027752 CH027753 /AY668

